

CARBURETOR SETTINGS

Factory carburetor setting for break-in procedure

The carburetor comes preset from factory and you have to start the break-in procedure with the following setting:

1 Main High-speed Needle (Upper)	0mm inside the needle body
2 Low-end Needle (Front)	0.5mm inside the needle body
4 Idle Adjustment Screw	Size measured with carburetor boot compressed approx 54mm

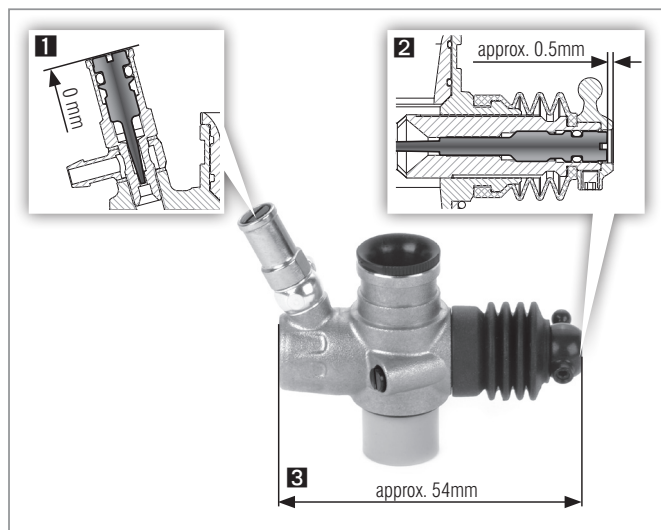

Basic Carburetor Setting after break-in procedure

After you have finished the break-in procedure this is the basic carburetor setting. Any time you get lost return back to this basic setting.

1 Main High-speed Needle (Upper)	approx. 0.8mm inside the needle body
2 Low-end Needle (Front)	approx. 0.8mm inside the needle body
4 Idle Adjustment Screw	Size measured with carburetor boot compressed approx 53.4mm

